

There are two types of panel wireway covers; blank (Figure A) and punched (Figure B). Blank covers are generally used in highly visible areas. Punched covers are used where a receptacle or power entry is installed.

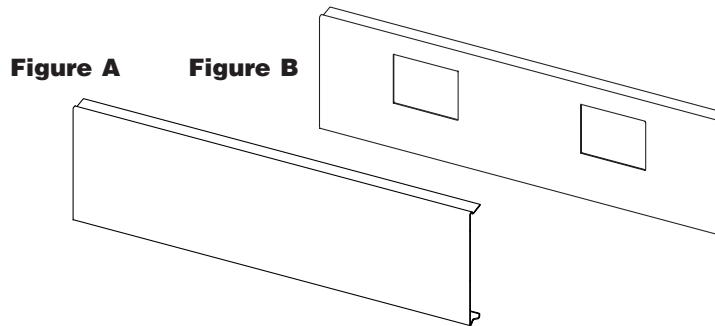

1 Install connector wireway covers first (Figure C).

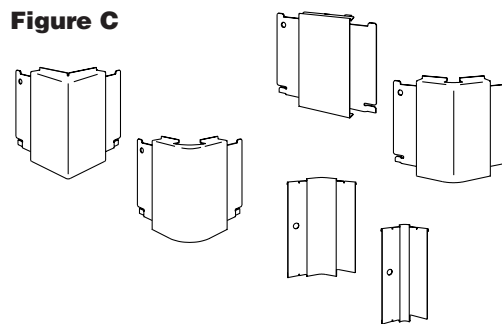

2 Hook tabs on cover onto panel wireway trough (Figure D).

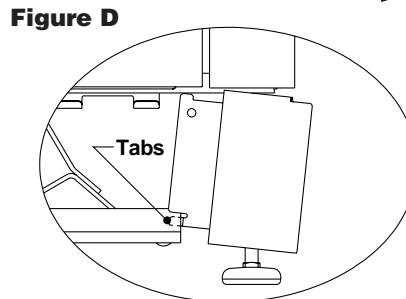

3 Push cover inward until cover engages on the bottom bracket (Figure E).

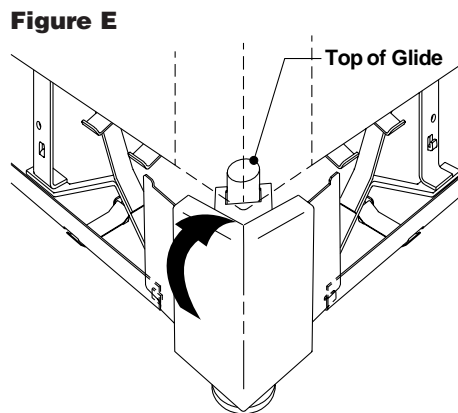
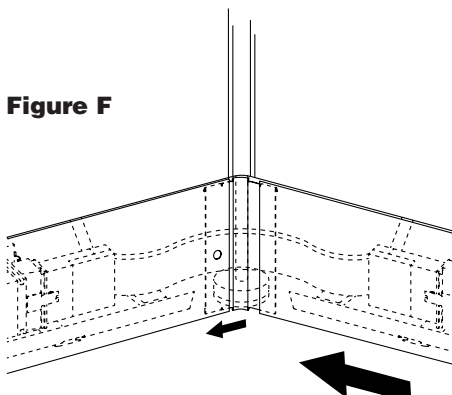

Figure F



Note:

All outside connector wireway covers install in a similar fashion. Inside covers are held in place by the adjacent covers (Figure F).

Cetra®

Assembly Instructions

Wireway Cover Installation

Recommended Tools

None Required



Telephone 800.482.1818
Fax 812.482.8300

Form #AISYCE016A-97
#1203306

Printed in U.S.A.
© 1997 Kimball International, Inc.

Proper product installation, in accordance with these instructions, is the responsibility of the installing agent. If you have any questions concerning these instructions, please call Kimball Customer Service.

Cetra®

Assembly Instructions

Wireway Cover Installation

Figure G

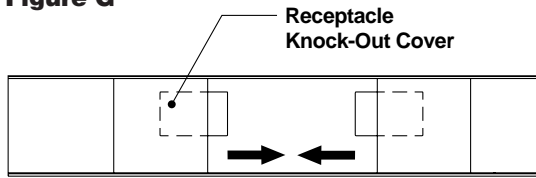

4 Slide the receptacle knockout covers towards the center of wireway cover or remove (Figure G).

5 Locate the two holes on the inside of the wireway cover, this is the bottom of the cover.

Figure H

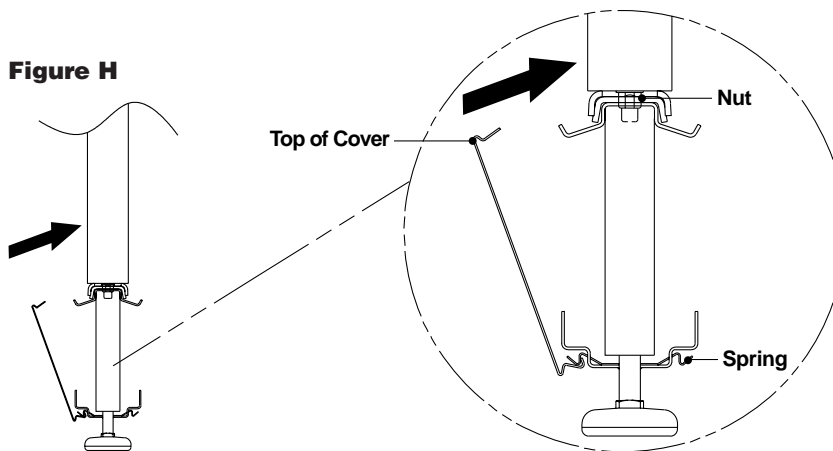

6 To install wireway cover, clip bottom of cover onto the springs on bottom of wireway trough (Figure H).

7 Push up on the bottom of the cover and rotate top toward panel (Figure I).

8 Clip top of cover on the wireway cover hanger (Figure I).

Tip:

If wireway cover does not fit securely verify the nut on the bottom connector is fully installed.

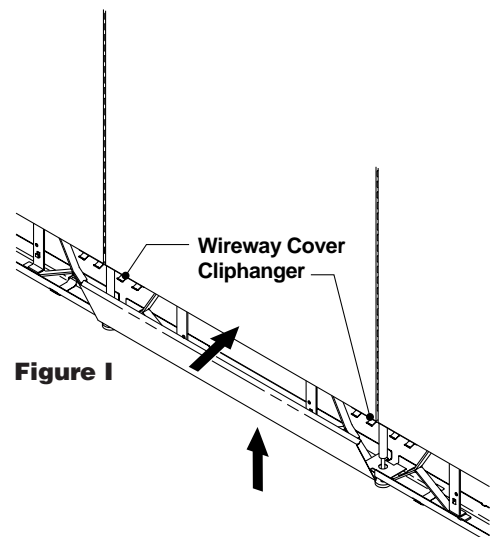

Figure I

Proper product installation, in accordance with these instructions, is the responsibility of the installing agent. If you have any questions concerning these instructions, please call Kimball Customer Service.