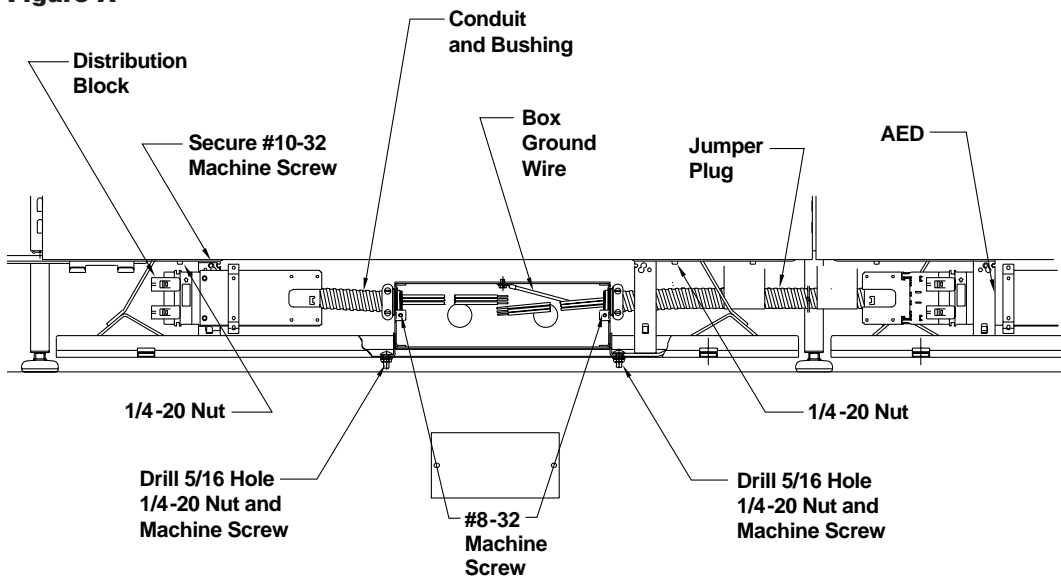

**Figure A**



**Note:**

Power entry connections must be made by a licensed electrician only. Installation must be in accordance with the National Electrical Code and Local Codes.

- Circuits must be wired with #12AWG wire utilizing #10AWG wire for common neutrals and fused at 15 amperes. No more than ten Duplex receptacles per branch circuit.
- Trade size 3/4" liquidtight conduit, fittings and wire are not supplied.
- Liquidtight conduit must not exceed 18" in length and be hard wired at both ends.
- Power entry box is unassembled from the factory.
- Jumper continues power into next panel.

**1** The AEF6 junction box replaces the AED36 and is installed by drilling (2) 5/16" holes in the bottom of the wireway trough. Mark position and drill holes. Position the box as near as possible to the jumper plug end. This allows proper length of distribution conduit (Figure A).

**2** Attach the box into the wireway trough using (2) 1/4"-20 nuts and machine screws provided (Figure A).

**Note:**

Wireway trough may be dropped from the panel by removing (2) 1/4"-20 nuts from bottom of panel (Figure A).

**3** Once the junction box is secured, cut distribution block conduit to length and fasten to power distribution support using #10-32 screw provided. Replace the anti-short bushing in conduit end before attaching to box (Figure A).

**4** Extend the jumper plug into the adjacent panel and connect to AED. Connect plug conduit end to junction box and secure (Figure A).

**Cetra®**

Assembly Instructions

**New York Floor Power Entry (AEF64, AEF66)**

**Recommended Tools**

- Variable Speed Drill with Torque Option
- 2" Diameter Chassis Punch
- 7/16" Socket
- Ratchet
- Tape Measure
- 5/16" Drill Bit

| Package Contents                       | Qty. |
|--|------|
| New York Floor Power Entry Box (AEF7*) | 1    |
| 1/4"-20 Phillips Machine Screws        | 2    |
| 1/4"-24 x 5/8" Phillips Machine Screws | 2    |
| Box Cover                              | 1    |
| Nut 1/4"-20                            | 2    |
| #10-32 Phillips Self Threading Screws  | 2    |



Telephone 800.482.1818  
Fax 812.482.8300

Form #AISYCE020  
#1210112

Printed in U.S.A.  
© Kimball International, Inc. 1996

Proper product installation, in accordance with these instructions, is the responsibility of the installing agent. If you have any questions concerning these instructions, please call Kimball Customer Service.

**Cetra®**

Assembly Instructions

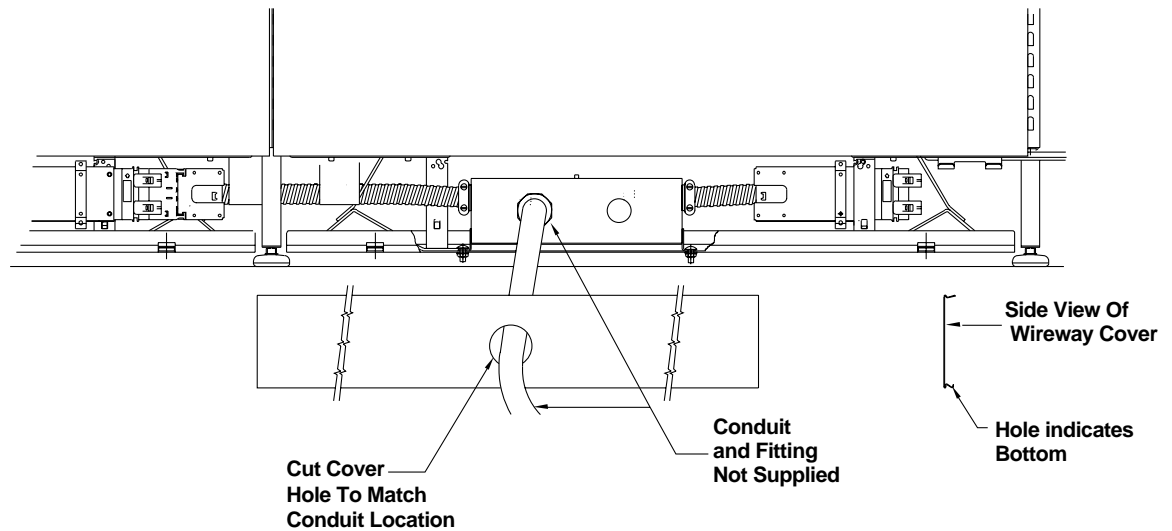
**New York  
Floor  
Power Entry  
(AEF64,  
AEF66)****Figure B****5**

Install 3/4" trade size liquidtight fitting in back of box. Install liquidtight conduit and color coded #12AWG wires and connect in approved method (Figure B).

**Note:**

Do not connect conduit to building supply until wireway cover is punched and conduit is inserted through hole in cover.

**Warning:**

Do not interconnect panels powered from different feed units. This can cause shock and fire hazard.

This panel system may be connected to more than one source of supply. All sources must be disconnected prior to any servicing. No single circuit may be powered by more than one source.

**6**

Punch hole in the wireway cover using a 2" diameter chassis punch.

**7**

Install cover plate on the front of the box using (2) #8-32 screws provided (Figure A).

**8**

Install remainder of components and check system prior to powering.

# Cetra®

Assembly Instructions

## Enhanced 10-Wire Wiring Schematic 4, 4, 2 Configuration

### 4, 4, 2 Configuration

Receptacles 1, 2, 3, and 4.

The Cetra enhanced ten-wire electrical system provides up to four circuits using four hot wires, four independent neutrals, a system ground and an isolated ground for circuits three and four.

Circuits 1, and 2 can be wired for general use, using separate neutrals and a common safety ground. Circuits 3 and 4 can be wired for computers using separate neutrals and a shared isolated ground.

### 120/208 Volt WYE 3 Phase 10-Wire

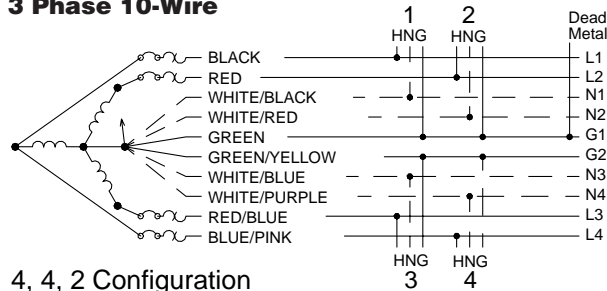

4, 4, 2 Configuration

### 120/240 Volt Delta Single Phase

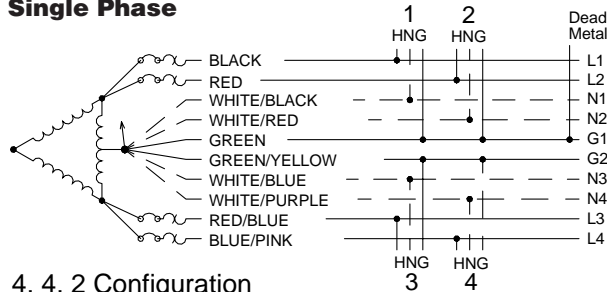

4, 4, 2 Configuration

### 120/240 Volt Single Phase

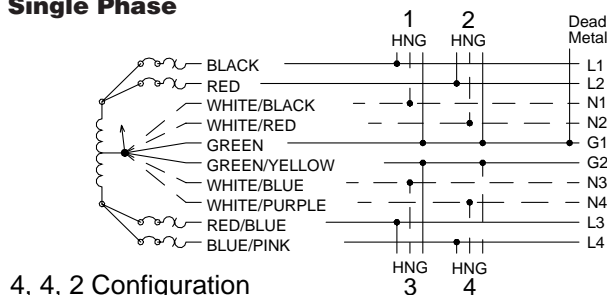

4, 4, 2 Configuration

# Cetra®

Assembly Instructions

## Enhanced 10-Wire Wiring Schematic 6, 2, 2 Configuration

### 6, 2, 2 Configuration

Receptacles 1, 2, 3, 4, 5, and 6.

The Cetra ten-wire electrical system provides up to six circuits using six hot wires, two increased size neutrals, a system ground and an isolated ground for the six circuits.

Ideally, a four-wire, WYE, 208 volt service provides the best utilization. Circuits 1, 2, and 3 can be wired for general use. Circuits 4, 5, and 6 which have their own increased size neutral and isolated ground, can be reserved for data and communications requirements.

Other power supplies such as 120/240 volt delta, 120/240 volt open delta and 120/240 volt single phase will be use circuits 1, 3 and 4, 6 with L2 (red) and L5 (red/blue) circuits taped off.

### 120/208 Volt WYE 3 Phase 10-Wire

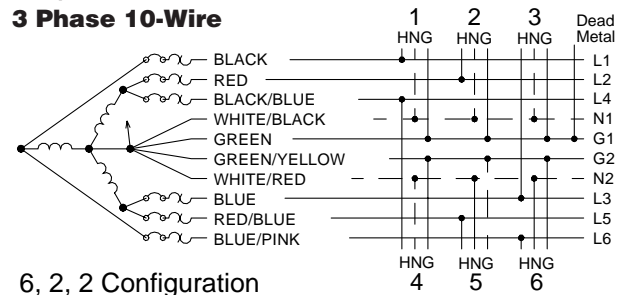

6, 2, 2 Configuration

### 120/240 Volt Delta Single Phase

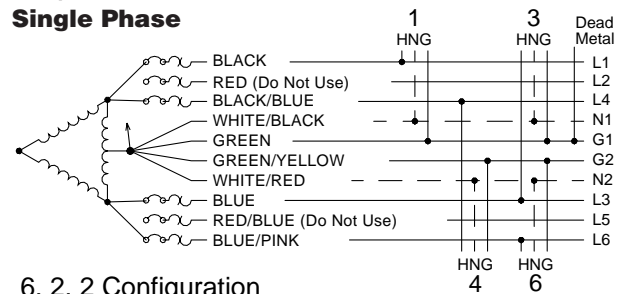

6, 2, 2 Configuration

### 120/240 Volt Single Phase

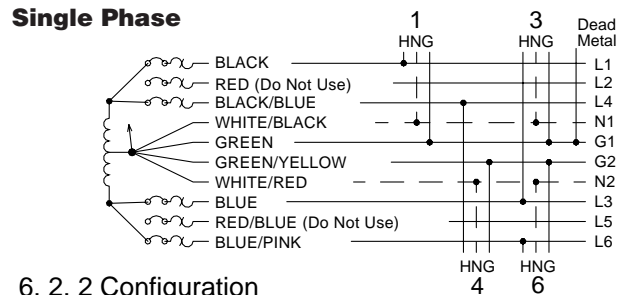

6, 2, 2 Configuration

Proper product installation, in accordance with these instructions, is the responsibility of the installing agent. If you have any questions concerning these instructions, please call Kimball Customer Service.