

Panel mounted worksurface brackets are provided in two types, left or right (Figures A & B). The top of the brackets should be located 22 3/4" from the top of the wireway cover for standard height and 19 3/4" for typing height (Figure C).

Figure A

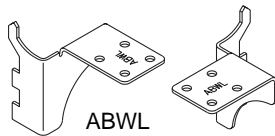

Figure B

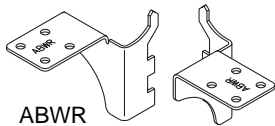

Figure C

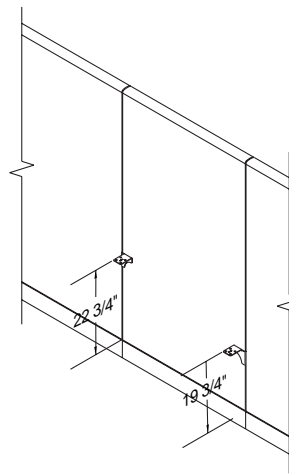

Figure D

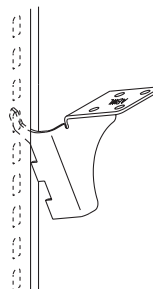
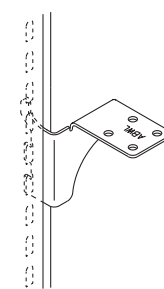

Figure E



1

Insert hook on the top of bracket into the "J" member at a 45 degree angle (Figure D).

2

Push the top of the bracket downward allowing locking tab to engage in the "J" member (Figure E).

3

Install a bracket at each panel joint in the worksurface layout.

Note: When installing the worksurface brackets along the center, you must alternate left brackets (ABWL) and right brackets (ABWR) to prevent a shortage of brackets (Figure F). If you run short of either left or right brackets, refer to alternate installation diagram (Figure G).

Note: A structural cantilever must be used in place of the standard worksurface brackets when the open kneespace is greater than 60" for 1 3/16" surfaces and 72" for 1 9/16" surfaces.

Figure F

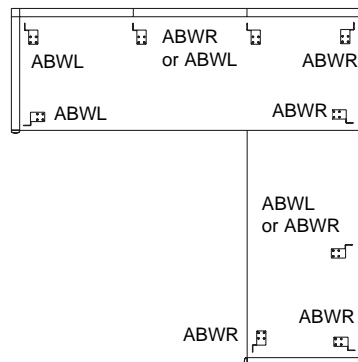
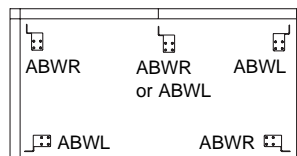

Figure G



Cetra[®] Footprint[®]

Assembly Instructions

Panel Mounted Worksurface Installation

Recommended Tools

- Tape Measure
- Variable Speed Drill with Torque Option
- #2 Phillips Head Bit



Telephone 800.482.1818
Fax 812.482.8300
www.furniture.kimball.com

Form #AISYCE014C-01
#1202058

Printed in U.S.A.
© 2001 Kimball International, Inc.

Cetra\ Footprint

Assembly Instructions

Panel Mounted Worksurface Installation

4 Place worksurface on clean, solid surface, back side facing up. Install the flat brackets on the “main” worksurface, approximately 2" from front edge and approximately 6" from back edge of the adjoining worksurface using the screws (ASC100) provided (Figure H). Ensure that the flat bracket attachment does not interfere with other brackets or components. Two flat brackets are required to join surfaces end to end or at a right angle.

5 Square all panels to aid in alignment and consistent reveals between worksurfaces and panels (Figure I).

6 Lay the worksurface on the brackets (Figure J).

Tip: Use an undersurface component as additional support until the worksurface bracket is secured to the surface.

7 Lay extension or filler worksurface onto brackets.

Note: When attaching two surfaces at a right angle, there will be a 1/8" gap between the wire manager and panel (Figure K). If there is no wire manager, the surfaces should align (Figure L).

8 Attach extension or filler worksurface to the flat brackets with screws (ASC100) provided (Figure M). Twelve screws required per bracket.

9 Adjust worksurface location to ensure alignment of surface joints with panel reveals, if applicable, and control gaps between panel and edges of worksurfaces. DO NOT press wire manager into panel.

10 Attach the worksurfaces to the worksurface brackets using the screws provided (Figure N). A minimum of two screws required per bracket.

Figure H

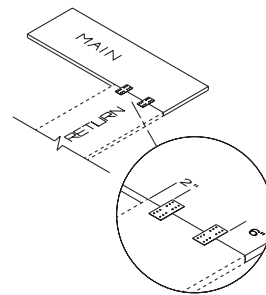

Figure I

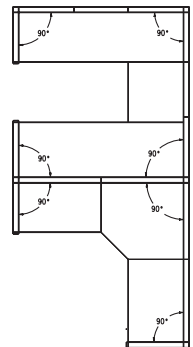

Figure J

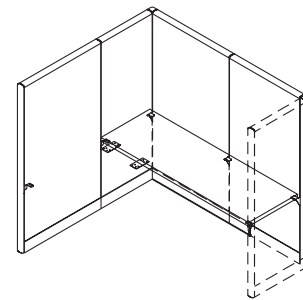

Figure K

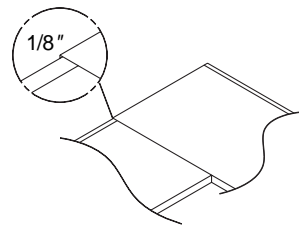

Figure L

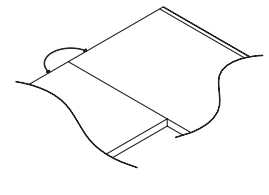

Figure M

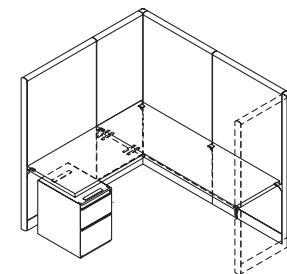
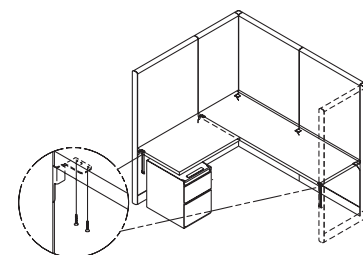

Figure N



Proper product installation, in accordance with these instructions, is the responsibility of the installing agent. If you have any questions concerning these instructions, please call Kimball Customer Care Teams.