

General Information

- These instructions provide the basic information to install an Interworks® End Panel, e.g. to create a freestanding desk.
- Arc worksurfaces are predrilled to accept End Panel in standard flush left/right position only.
- For Rectangular and non-standard position, worksurface must be drilled.
- Process is similar for both Full and Half End Panel. Full End Panel is illustrated.
- Half End Panel is often used to create a freestanding Corner desk.
- When an Undersurface Lateral File is used, a Full End Panel is required to support desk on the same side as the File.
- One person can perform all operations, although two may be required to handle larger, heavier units.

Tools Required

- Drill with $\frac{1}{8}$ " and #2 Phillips tip bits
- $\frac{5}{16}$ " Hex socket
- Level

Hardware

- Metal to worksurface: #10x1" Phillips pan head particleboard screws.
- Metal to metal: #10x $\frac{1}{2}$ " Hex washer head drill screws.

End Panel Installation

- End Panels include brackets for attaching to worksurface and predrilled holes to secure Modesty Panel (Figure A).
1. Determine location of End Panel, left or right. Relocate the two glides to the opposite side of support as needed.
 2. For Arc worksurface, use predrilled holes as a guide. For Rectangular worksurface, inset End Panel approximately $\frac{1}{8}$ " from front and back of worksurface, and approximately $\frac{1}{16}$ " from side of worksurface. Secure front and rear End Panel/Worksurface Brackets to worksurface with four #10x1" screws per bracket (Figure B).
 3. Turn End Panel upside down and align to installed brackets. Holes in the End Panel should be to the INSIDE and the glides should be facing UP. Secure loosely with two #10x $\frac{1}{2}$ " screws (Figure C).
- NOTE:** After you have installed the Modesty Panel, you need to retighten all screws.

Figure A

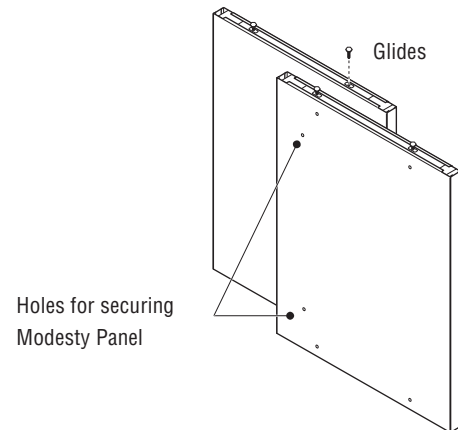

Figure B

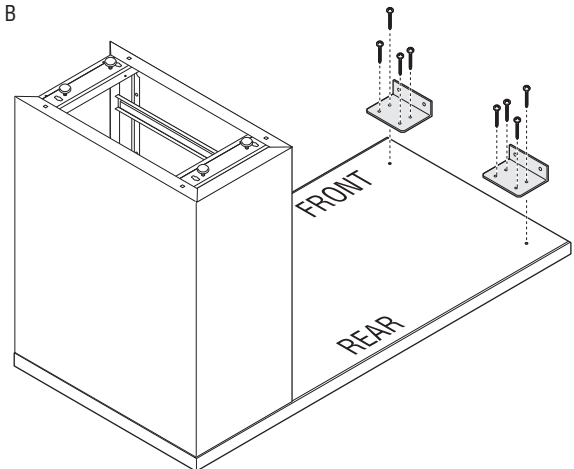
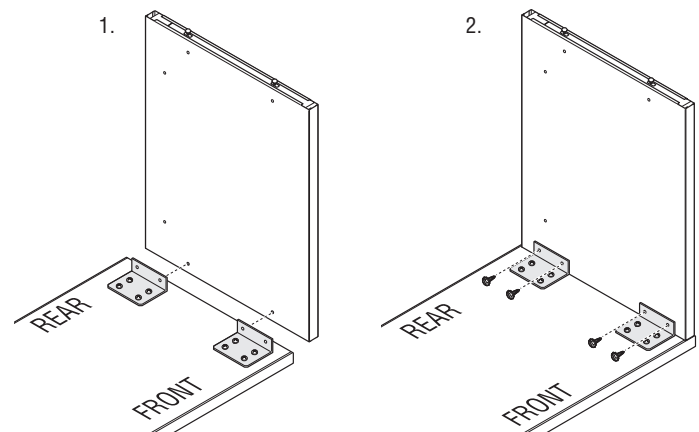

Figure C



Proper product installation, in accordance with these instructions, is the responsibility of the installing agent. If you have any questions concerning these instructions, please call your Customer Care Team.