

General Information

- These instructions provide the basic information to install a Decorative Support Leg onto any Interworks® systems or modular worksurface or ICS style systems worksurface.
- D Shape, U Shape and Extended U Shape worksurfaces are predrilled for installation.
- One person can perform all operations.

Tools Required

- Drill with #2 Phillips tip bit
- Level

Hardware

- #10x1" Phillips pan head drill screws.

Installation

- The Decorative Support Leg provides the main support for the top.
 - A Privacy Panel can be secured to Decorative Support Leg. Refer to Sheet #HAIWW009.
 - D Shape, U Shape and Extended U Shape worksurfaces are predrilled for Column Base installation (Figure A).
1. Turn worksurface upside down.
 2. Locate two predrilled holes on the underside of the worksurface. These are for attaching Column Base.
 3. **Position template (pages 2 and 3 of this assembly sheet) over predrilled holes** (Figure B).
 4. Place Decorative Support Leg onto template and align hole locations for positioning Decorative Support Leg (Figure C).
NOTE: Be sure to position Decorative Support Leg so that the side with weld-beading faces inward.
 5. Remove template and secure Decorative Support Leg to underside using ten #10x1" screws (Figure D).
 6. Position worksurface and check for square and level. Adjust by turning glides at the base of the Decorative Support Leg.

Figure A

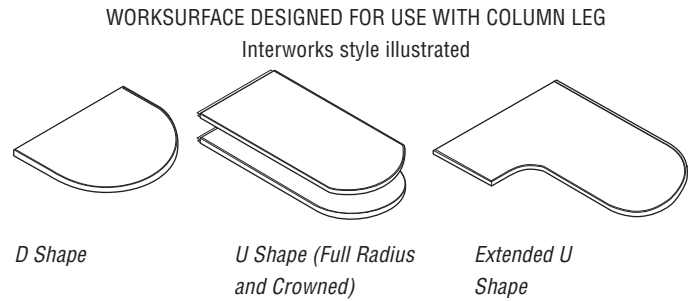

Figure B

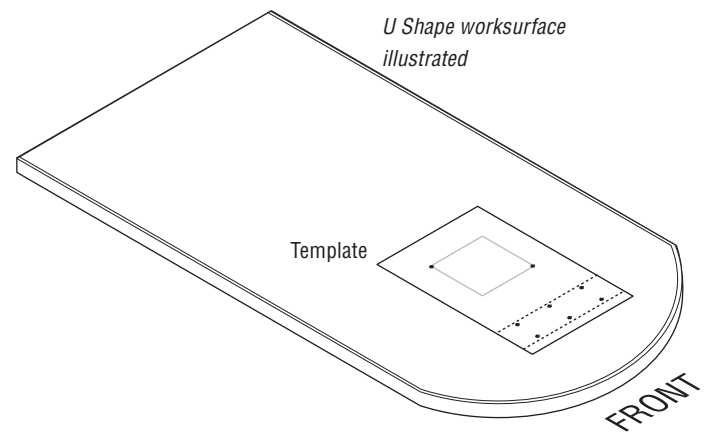

Figure C

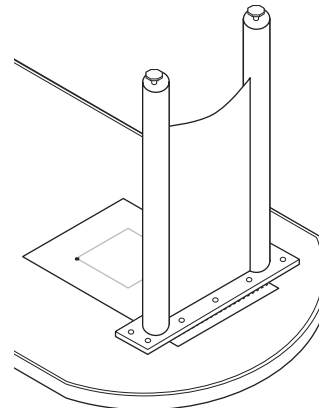
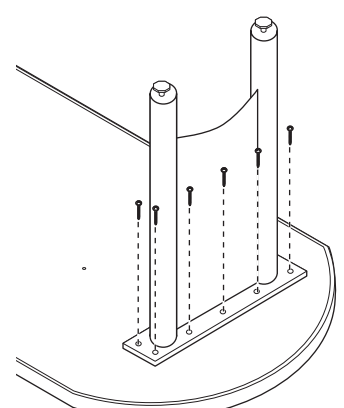

Figure D



Proper product installation, in accordance with these instructions, is the responsibility of the installing agent. If you have any questions concerning these instructions, please call your Customer Care Team.

Information:

- Follow steps on page 1.
- This template is shown actual size. Measurement is not necessary if this template is used properly.
- Place template onto worksurface so that approach side (with the rounded edge) is to the right.

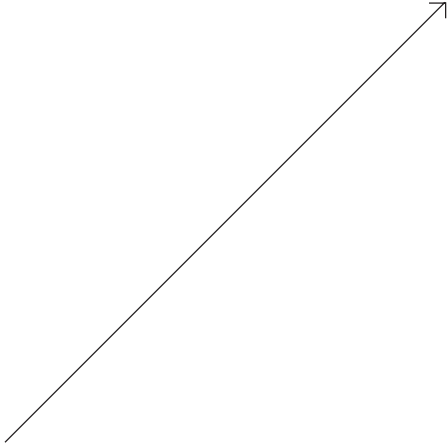

Predrilled holes on underside of worksurface for installing Column Base. Use these holes only to position template.





**Holes for positioning
Decorative Support Leg.**



**Center holes (see
Figure C, page 1).**



Notes: