

General Information

- These instructions provide the basic information to install a Privacy Panel onto any Interworks® systems or modular worksurface or ICS style systems worksurface (Bullet worksurfaces illustrated).
- Privacy Panel is designed for use with Bullet worksurfaces. It can be installed to a Decorative Support Leg or Gusset Bracket (Figure A) or End Panel.
- Privacy Panel “user” side is smooth.
- One person can perform all operations.

Tools Required

- Drill with $\frac{1}{8}$ " and #2 Phillips tip bits
- Level

Hardware

- (5) 8-32x $\frac{3}{8}$ " Phillips Panhead screws
- (2) 10-24x1" Phillips Panhead screws

Installation to Decorative Support Leg

1. Turn worksurface upside down.
2. Install Decorative Support Leg first (refer to Assembly Sheet HAIWW008).
3. Position Privacy Panel perpendicular to tube leg of Decorative Support Leg so that bottom hole in Privacy Panel is about 3" from the underside of worksurface (Figure B).
4. Mark hole locations and drill holes with $\frac{1}{8}$ " drill bit.
5. Secure Privacy Panel to Decorative Support Leg using three #8-32x $\frac{3}{8}$ " Panhead screws. Make sure Privacy Panel is perpendicular.

Installation to Gusset Bracket

1. Position Gusset Bracket into inside flange of Privacy Panel. Secure with two #8-32x $\frac{3}{8}$ " Panhead screws.
2. Ensure Privacy Panel is still perpendicular to Decorative Support Leg and secure Gusset Bracket to worksurface using two #10-24x1" Panhead screws (Figure D).

Installation to End Panel

1. Mount End Panel flush with worksurface.
2. Drill two $\frac{1}{8}$ " holes into End Panel to match Privacy Panel and secure using two #8-32x $\frac{1}{8}$ " Panhead screws.

Figure A

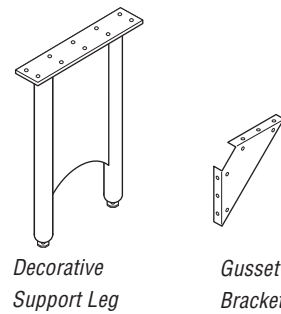

Figure B

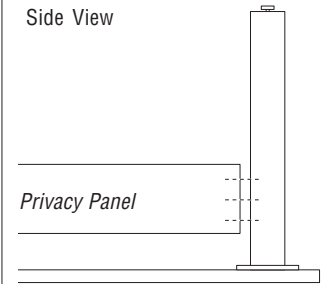

Figure C

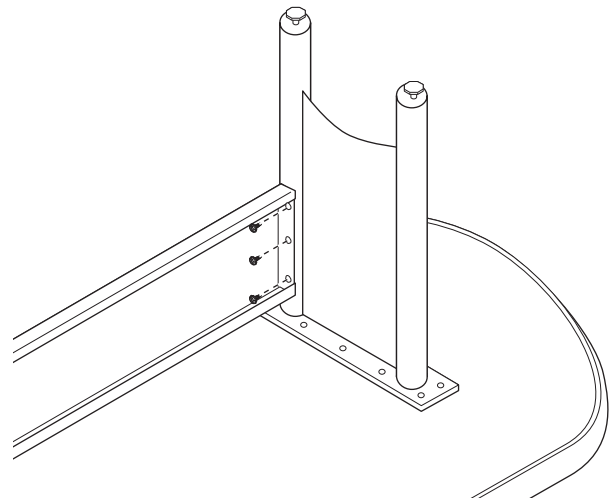
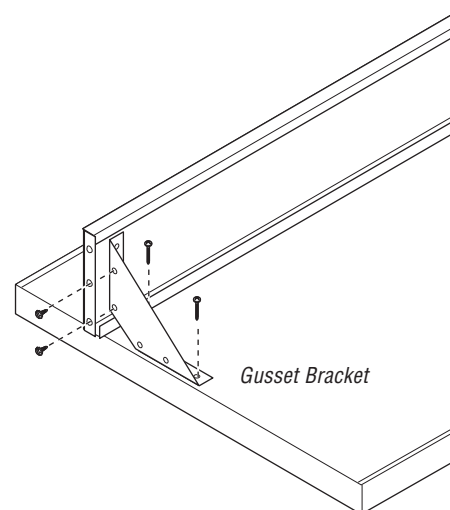

Figure D



Proper product installation, in accordance with these instructions, is the responsibility of the installing agent. If you have any questions concerning these instructions, please call your Customer Care Team.