

General Information

- These instructions provide the basic information to install a Gusset Bracket onto any Interworks® systems or modular worksurface or ICS style systems worksurface.
- Gusset Bracket is non-handed.
- Gusset Bracket is designed for use with a Worksurface Support Panel, Return Support Panel or Privacy Panel, all of which are predrilled for bracket attachment (Figure A). It can also be used with an End Panel, which is not predrilled, e.g. to create a “freestanding” table.
- One person can perform all operations.

Tools Required

- Drill with 1/8" drill bit and Phillips head #2 tip
- Level

Hardware

- 8-32x3/8" Phillips Panhead screws
- 10x1" Phillips particleboard screws
- #10x1/2" Hex head drill tip screws

Figure A

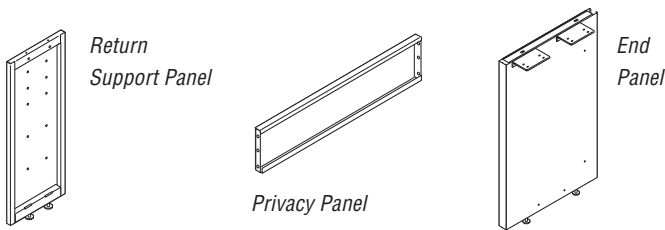

Installation to Support Panel

1. Install Support Panel to worksurface (see #HAIWW015).
2. Align holes in Gusset Bracket to corresponding holes in Support Panel and secure using three #10x1/2" Hex head drill tip screws (Figure B).
3. Secure Gusset Bracket to worksurface using three 10x1" Phillips particleboard screws.

Installation to Privacy Panel

1. Position Gusset Bracket into inside flange of Privacy Panel. Secure with two #8-32x3/8" Panhead screws (Figure C).
2. Ensure Privacy Panel is still perpendicular to Decorative Support Leg and secure Gusset Bracket to worksurface using three #10x1" Phillips particleboard screws.

Figure B

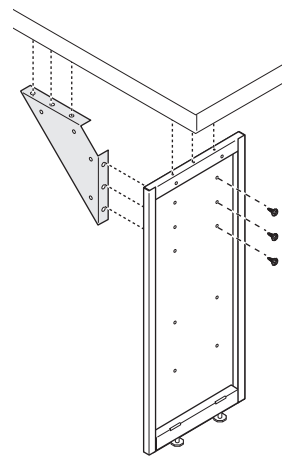
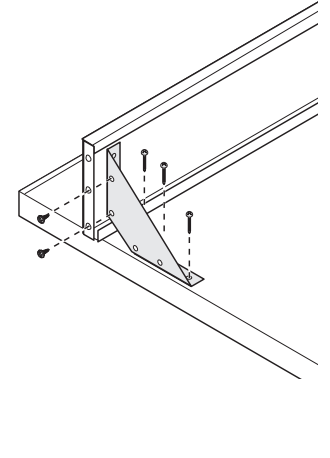

Figure C



Installation to End Panel

1. Locate two vertical holes in End Panel for attaching Modesty Panel. These holes indicate the location of the substructure inside the End Panel. Measure distance from these holes to closest edge of End Panel, approximately 4 1/8". Mark same distance at opposite side of End Panel (Figure D).
2. Place first Gusset Bracket against End Panel, in-line with pre-drilled holes. Mark Gusset Bracket hole locations and install Gusset Brackets with three #10x1/2" screws per bracket.
3. Check for vertical plumb of Gusset Brackets and secure each to worksurface using three #10x1" screws each bracket.

Figure D

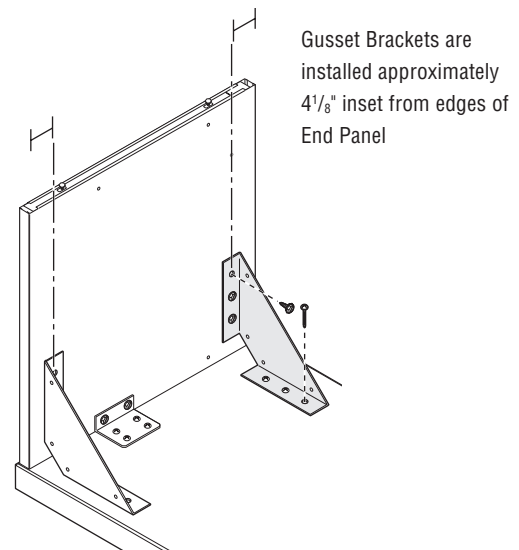

Proper product installation, in accordance with these instructions, is the responsibility of the installing agent. If you have any questions concerning these instructions, please call your Customer Care Team.