

# Footprint® Support

## Cetra® Panel Mounted Worksurface

### Tools Required

- Tape Measure
- Drill with torque option
- #2 Philips head bit
- #2 R-2 square screwdriver bit

### Installation

**Note:** Panel mounted worksurface brackets are provided in two types, left or right. (Figures A & B). The top of the brackets should be located 22 3/4" from the top of the wireway cover for standard height and 19 3/4" for typing height. (Figure C).

1. Insert hook on the top of bracket into the panel frame slot at a 45° angle. (Figure D).
2. Push the top of the bracket downward allowing locking tab to engage in the panel slot. (Figure E).
3. Install a bracket at each panel joint in the worksurface layout.

**Note:** When installing the worksurface brackets along the center, you must alternate left brackets and right brackets to prevent a shortage of brackets. (Figure F). If you run short of either left or right brackets, refer to alternate installation diagram. (Figure G).

**Note:** A structural cantilever must be used in place of the standard worksurface brackets when the open kneespace is greater than 48" for 1 3/16" surfaces and 60" for 1 9/16" sur-

Figure C

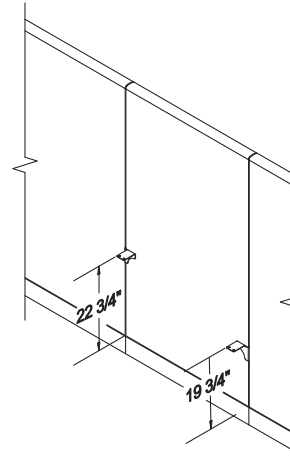

Figure D

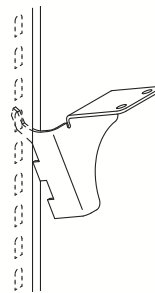

Figure E

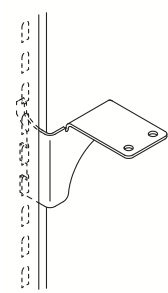

Figure A

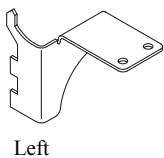

Figure B

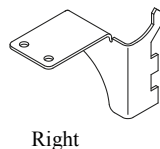

Figure F

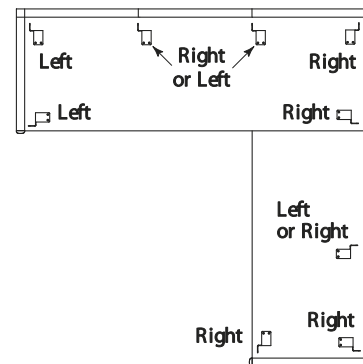
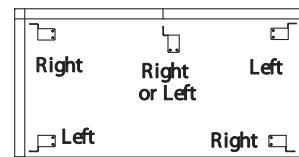

Figure G



# Footprint® Support

## Interworks EQ® Panel Mounted Worksurface

### Installation (continued)

4. Place worksurface on clean, solid surface, back side facing up. Install the flat brackets on the "main" worksurface, approximately 2" from front edge and approximately 6" from back edge of the adjoining worksurface using the screws provided. (Figure H). Ensure that the flat bracket attachment does not interfere with other brackets or components. Two flat brackets are required to join surfaces end to end or at a right angle.
5. Square all panels to aid in alignment and consistent reveals between worksurfaces and panels. (Figure I).
6. Lay the worksurface on the brackets. (Figure J).  
Tip: Use an undersurface component as additional support until the worksurface bracket is secured to the surface.
7. Lay adjoining worksurface onto brackets.

**Note:** When attaching two surfaces at a right angle, there will be a 1/8" gap between the wire manager and panel. (Figure K). If there is no wire manager, the surfaces should align. (Figure L).

8. Attach adjoining worksurface to the flat brackets with screws provided. (Figure M). Eight screws required per bracket.
9. Adjust worksurface location to ensure alignment of surface joints with panel reveals, if applicable, and control gaps between panel and edges of worksurfaces. DO NOT press wire manager into panel.
10. Attach the worksurfaces to the worksurface brackets using the screws provided. (Figure N). A minimum of two screws

Figure H

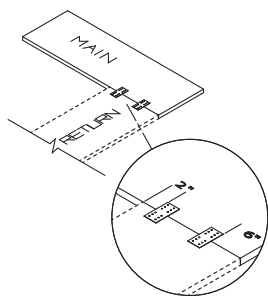

Figure I

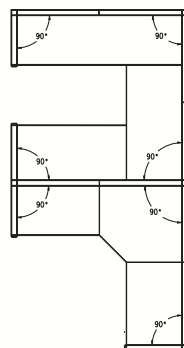

Figure J

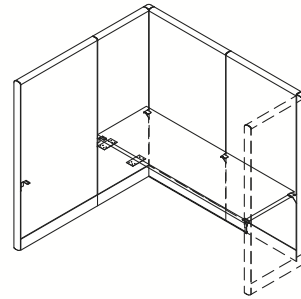

Figure K

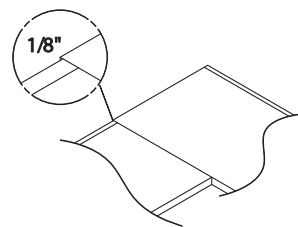

Figure L

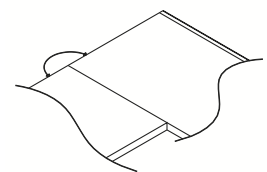

Figure M

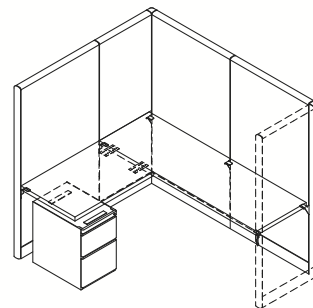

Figure N

