

# Footprint®

## Transaction Counter on Interworks® EQ

### Tools Required

- Variable Speed Drill
- #2 Phillips Tip Bit

### Package Contents

- #10 x 1" Phillips Panhead Screws

### General Information

- Transaction counter width must equal panel width.
- Two sets of left and right handed support brackets are included with each counter top.
- One person can perform all operations.
- Panels and finish channels must be properly installed, squared and leveled prior to counter top installation.
- Route all communications prior to installing counter.

### Installation

1. Locate position where counter top will be installed into panel. Insert each set of left and right handed support brackets into top slot of panel side rail. (Figure A).  
*Note: Panel top cap is not removed. All panel finish trim should already be installed.*
2. Lay counter top onto brackets and center top approximately 6½" overhang on either side of top.
3. Secure with #10 x 1" screws provided, two screws per bracket.

Figure A

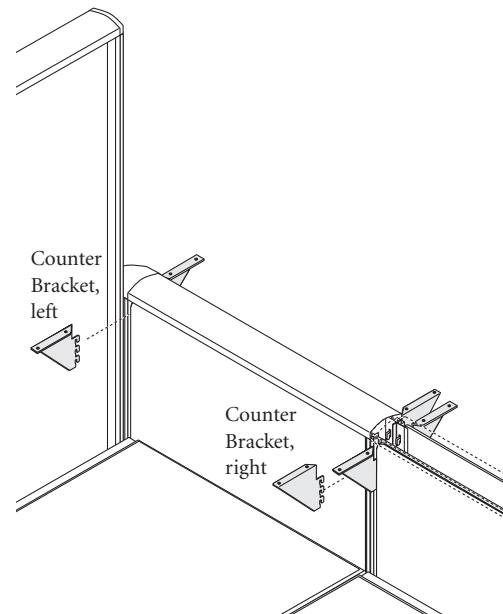

Figure B

