

Footprint[®]

Bevel Profile Overhead Bracket Kit For Xsite[®]

Tools Required

- Cordless Drill/Driver
- Tape Measure
- #2 Phillips Screwdriver Bit

Installation

1. Tilt bracket up at 15° angle and engage center tab into Xsite Traxx[®]. Lower bracket to engage hooks into Xsite Traxx. Repeat for opposite bracket. (Figure A).
2. Locate lock clips installed in upper rear corners of overhead and remove them. (Figure B).
3. Measure and place outside edges of brackets at same width as overhead. (36" apart for 36" overhead, for example.) (Figure C).

Figure A

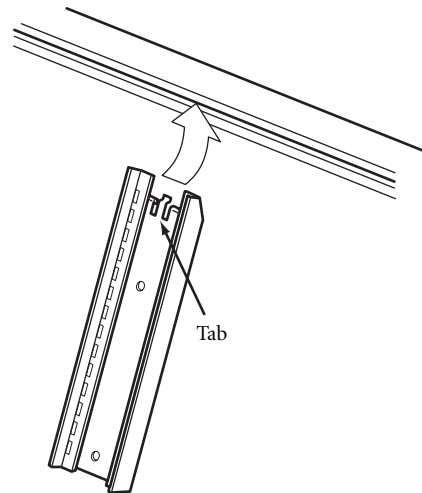

Figure B

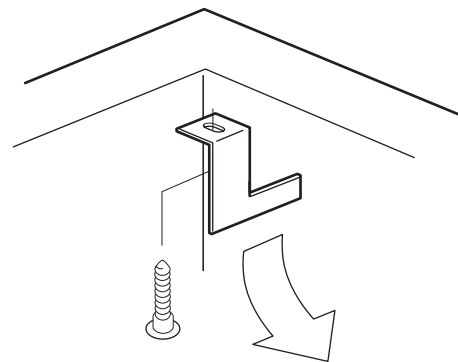
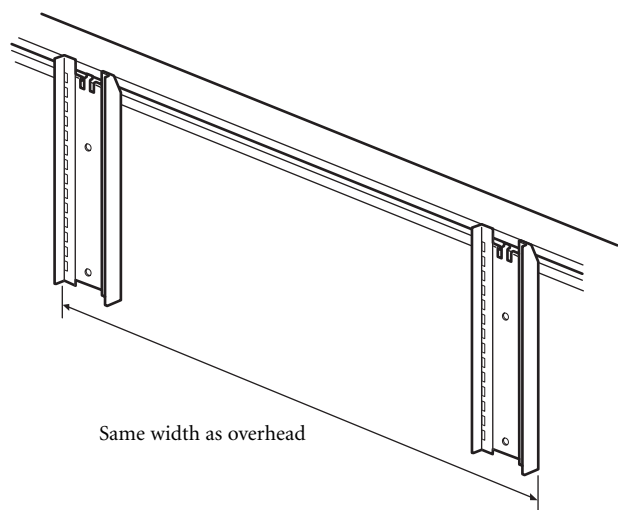

Figure C



Proper product installation, in accordance with these instructions, is the responsibility of the installing agent. If you have any questions concerning these instructions, please call Kimball Office Customer Care.

Kimball[®]Office

Footprint

Installation (continued)

4. With two people, lift overhead up and tilt at 15° angle and engage hooks on back of overhead into slots of attachment brackets. (Figure D). Fully seat hooks into slots.
5. Position lock clips so unnotched flange engages alongside second hook in rear brackets. Reinstall screw into each clip. (Figure E).
6. Tilt overhead out slightly. Carefully slide support bar between overhead and tile until mounting plates are flush with bottom of overhead. Attach with four #10 x 1/2" screws provided. (Figure F).
7. Tilt overhead out slightly and slide to final position.

Figure D

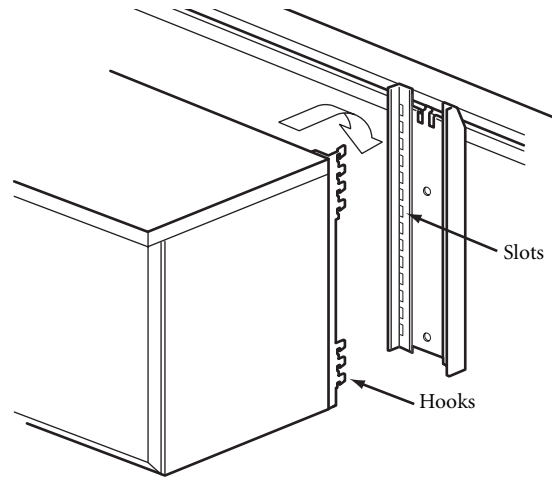

Figure E

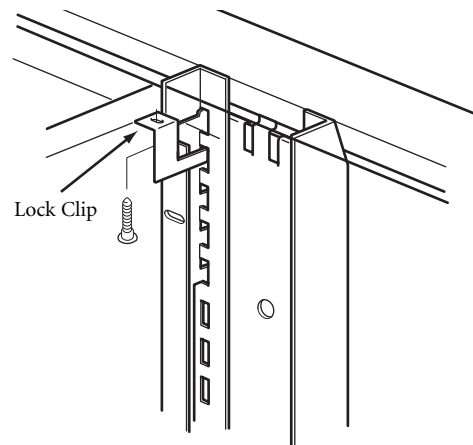

Figure F

