

Fluent

Glass Tables

Tools Required

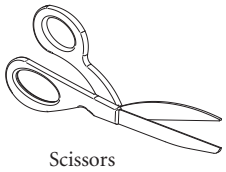

Scissors

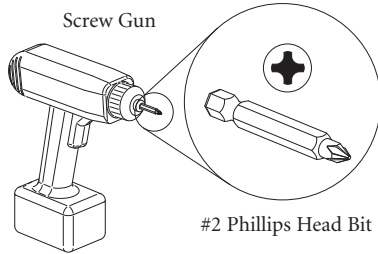

Screw Gun

#2 Phillips Head Bit

Package Contents

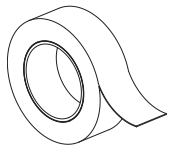

Double Sided Adhesive Tape



M4 Machine Screw

Installation

Note: It is recommended that three (3) persons be used for assembling glass table units.

1. Place the worksurface frame/rails on a clean, soft surface, underside facing up. Align the leg assembly to the eight predrilled holes of rails and fasten. (Figure A).
2. Flip unit right side up. Cut six strips of double-sided adhesive tape and place them along the edges of rails as shown. **DO NOT** remove the film backer to expose the adhesive at this time. (Figure B).

Note: The rails and underside of glass top **MUST** be clean, dry, and free of any dirt or residue to assure adequate adhesion.

3. Carefully set glass worksurface on leg assembly. Center up all four sides of top so that the outside edge of glass is flush with outside edge of legs. (Figure C).

Figure A

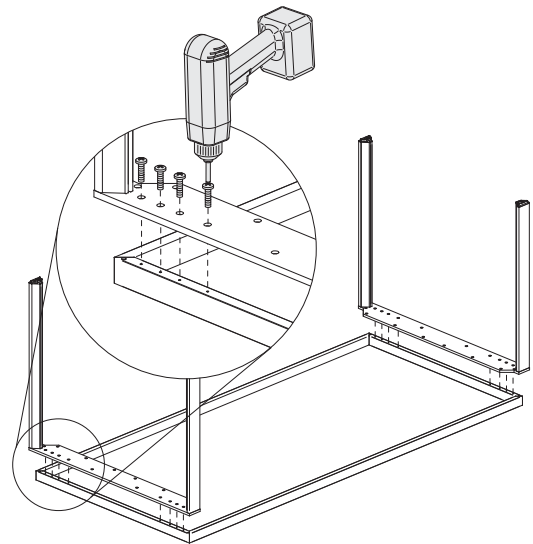

Figure B

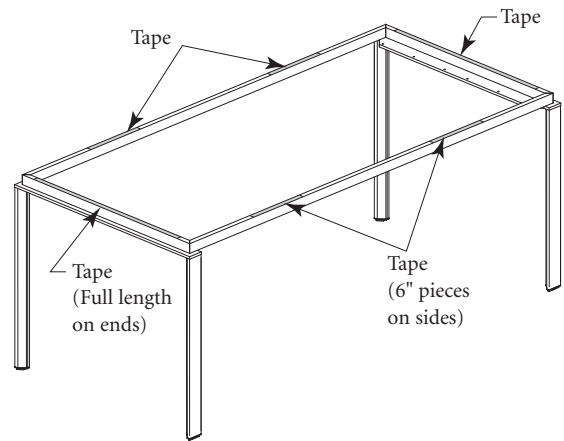
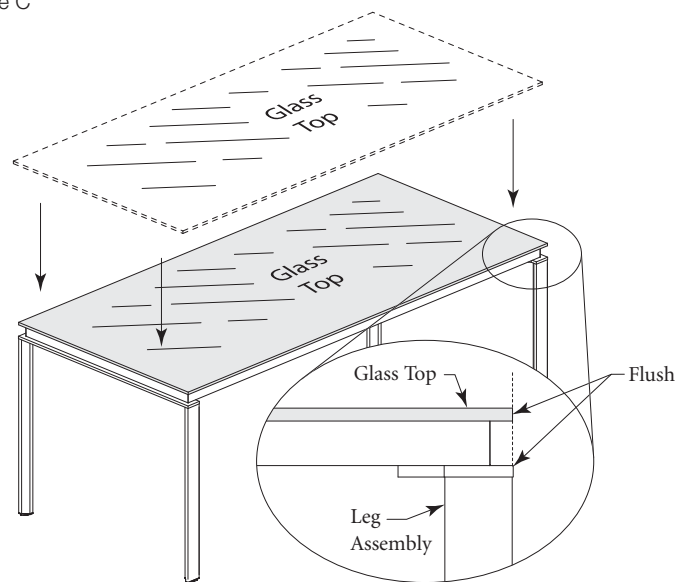

Figure C



Proper product installation, in accordance with these instructions, is the responsibility of the installing agent. If you have any questions concerning these instructions, please call Kimball Office Customer Service.

Kimball[®]Office

Fluent

Installation (continued).

4. Step 4 requires three people. Position one person at each end of table. While one person tilts one end of the glass top up, the other will need to be at opposite end, securing top in position eliminating shifting or sliding of glass top. While the double sided adhesive tape is exposed on half of the table, a third person will need to peel off film backer. Now gently lower the raised end and tilt up opposite side, careful not to move table top from side-to-side or front-to-back. Peel off remaining adhesive film backer and lower table top back to position. (Figure D).
5. Check that all four sides remain flush and apply direct downward pressure on for glass top to adhere to leg assembly. (Figure E).

Figure D

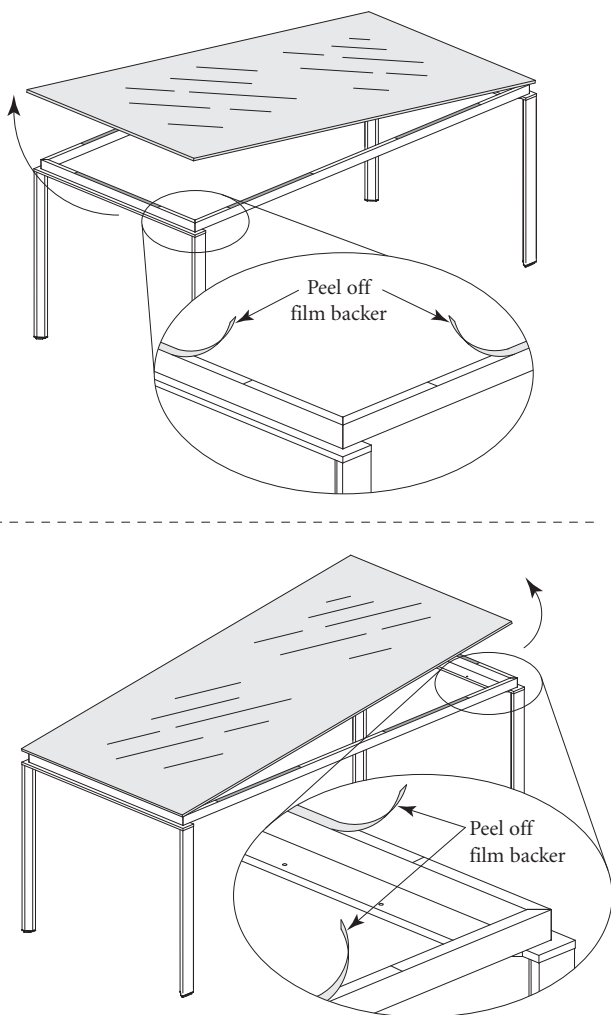
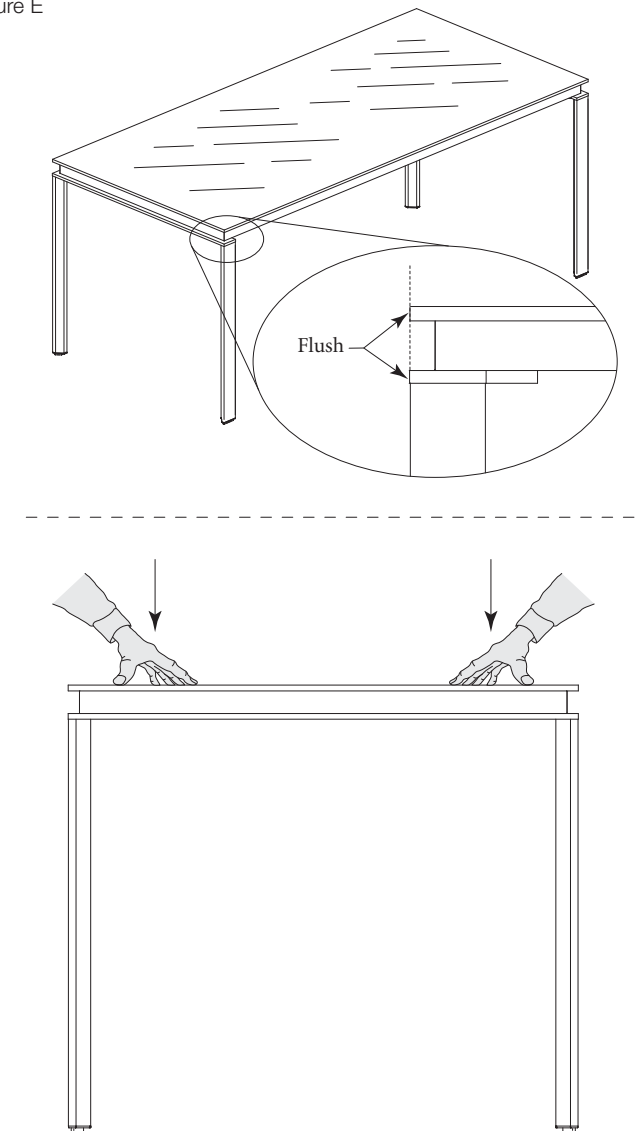

Figure E



Printed in U.S.A. © 2009 Kimball International, Inc. T 800.482.1818 F 812.482.8300

Proper product installation, in accordance with these instructions, is the responsibility of the installing agent. If you have any questions concerning these instructions, please call Kimball Office Customer Service.

Kimball[®]Office