

### Highback Shelf

#### Tools Required

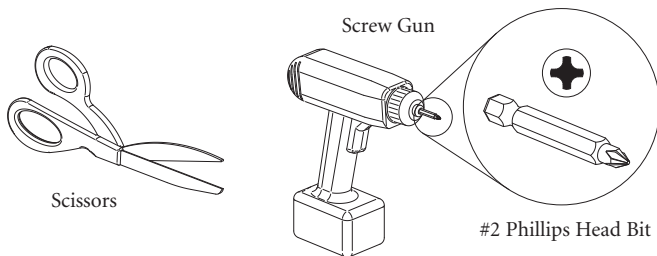

#### Package Contents



#### Installation

**Note:** It is recommended that two (2) persons be used to lift and flip highback shelf units.

##### Without Workwall

1. Place the shelf on a clean, soft surface, underside facing up. Align leg assembly centered front to back and press flush up against edge of pan. Attach legs using nine (9) #10 x 1" panhead screws provided. (Figure A).
2. The wire manager is attached with double-sided adhesive tape. Peel off film backer from tape and apply wire manager to inside of leg. To securely attach a highback shelf to a worksurface, cut four pieces of double-sided adhesive tape and place on bottom of all four legs. Remove the film backer to expose the adhesive. (Figure B).
3. Flip assembled highback right side up and place on desk unit. (Figure C).

**Note:** The worksurface **MUST** be clean, dry, and free of any dirt or residue to assure adequate adhesion.

**Caution:** The tape is a very strong adhesive and bonds instantly to any surface it is applied to.

Figure A

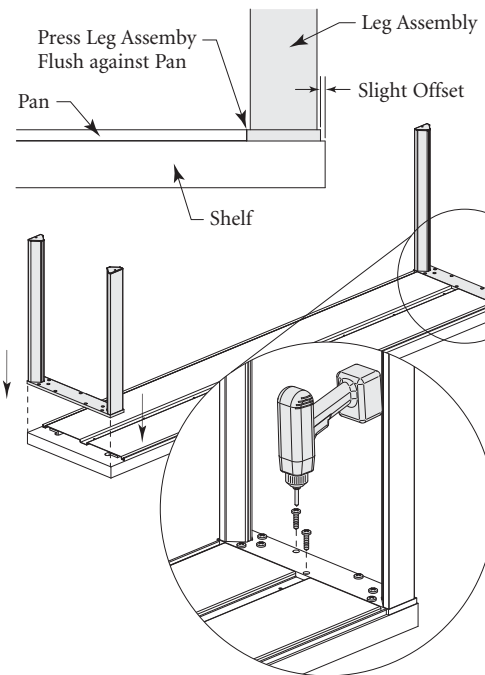

Figure B

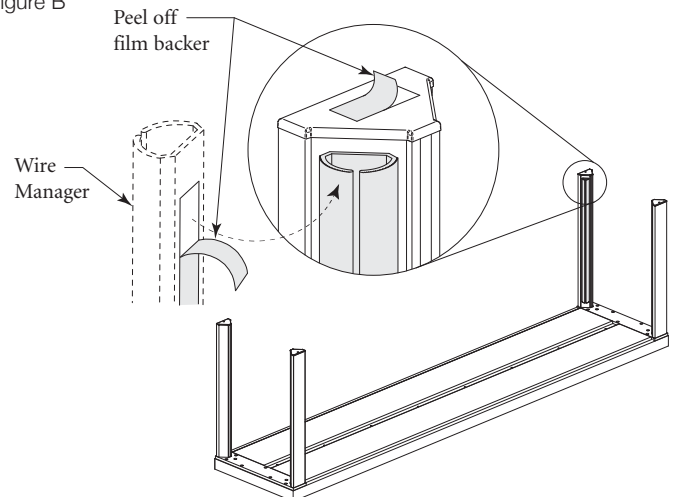
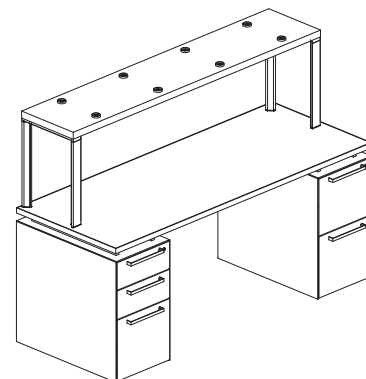

Figure C



Installation (continued).

### With Workwall

- Place the shelf on a clean, soft surface, underside facing up. Flip the legs and workwall upside down, and slide the workwall into legs. (Figure D).

**Important:** The top and bottom of workwall is determined by a feature inside the tool rail. The surface in the tool rail that has a "V" goes to the top, the flat surface goes to bottom.

- Align leg assembly centered front to back and flush up against edge of pan. Attach legs using nine (9) #10 x 1" panhead screws provided. (Figure E).
- Apply felt along bottom edge of workwall. The wire manager is attached with double-sided adhesive tape. Peel off film backer from tape and apply wire manager to inside of leg. To securely attach a highback shelf to a worksurface, cut four pieces of double-sided adhesive tape and place on bottom of all four legs. Remove the film backer to expose the adhesive. (Figure F).
- Flip assembled highback right side up and place on desk unit. (Figure G).

**Note:** The worksurface **MUST** be clean, dry, and free of any dirt or residue to assure adequate adhesion.

**Caution:** The tape is a very strong adhesive and bonds instantly to any surface it is applied to.

Figure D

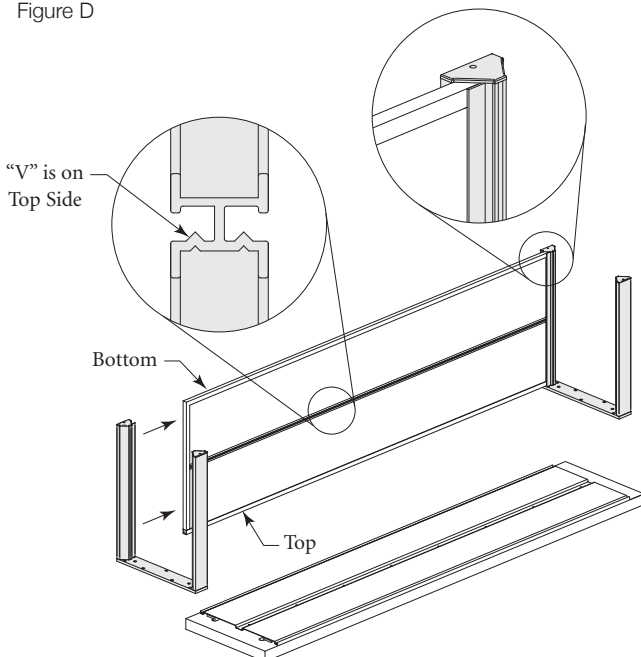

Figure E

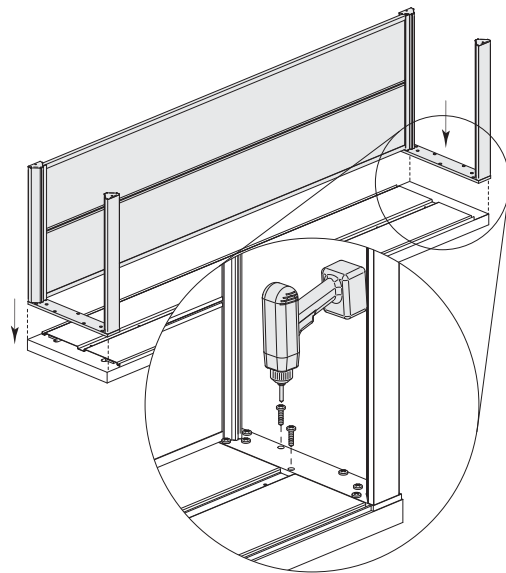

Figure F

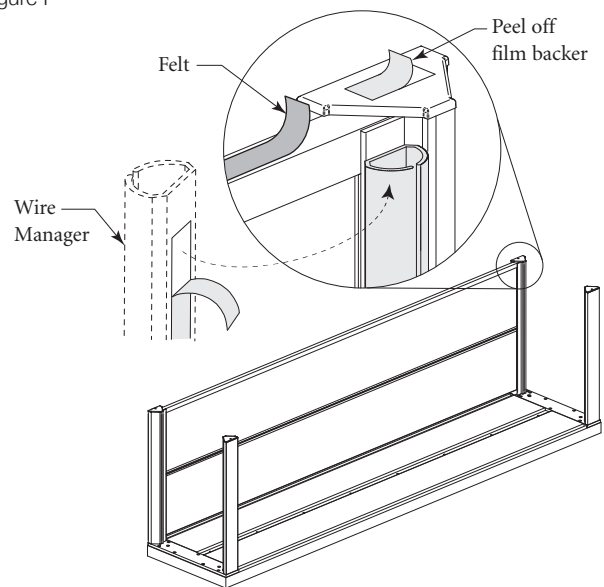

Figure G

