

Fluent

Hinge Adjustment and Shelf Adjustment

Tools Required

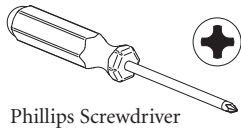

Phillips Screwdriver

Installation

1. Side Adjustment:

Turn front screw clockwise to increase door overlay, counterclockwise to decrease overlay. (Figure A).

2. Depth Adjustment:

Loosen back screw. Adjust door to desired position and tighten screw. (Figure B).

3. Height Adjustment:

Loosen screw(s) on the mounting plate. Adjust door to position and tighten screws. (Figure C).

4. Door Removal and Installation:

To remove, pull release lever back (Figure D). To re-install, place the hinge on the mounting plate and push the rear of the hinge with finger pressure. The snap sound confirms a secure attachment.

5. Shelf Adjustment:

Remove screws in bottom of shelf brackets. Remove shelf. Insert brackets at desired level. Replace shelf. (Figure E).

Note: Screws were used for shipping purposes.

For additional security, adjustable shelves can be fastened into position using original shipping screws.

Figure A

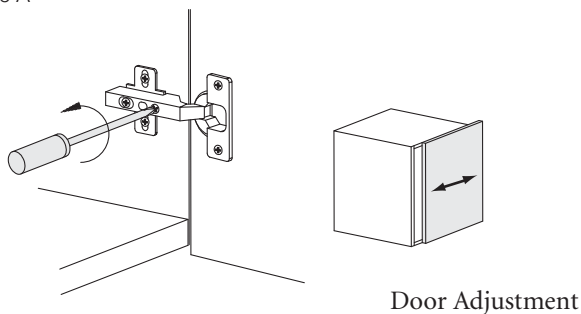

Figure B

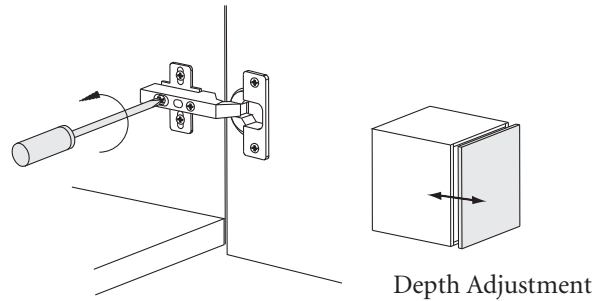

Figure C

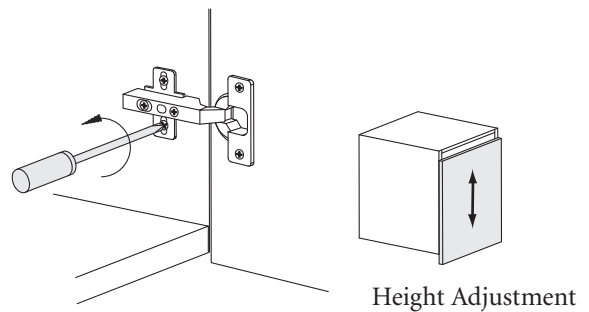

Figure D

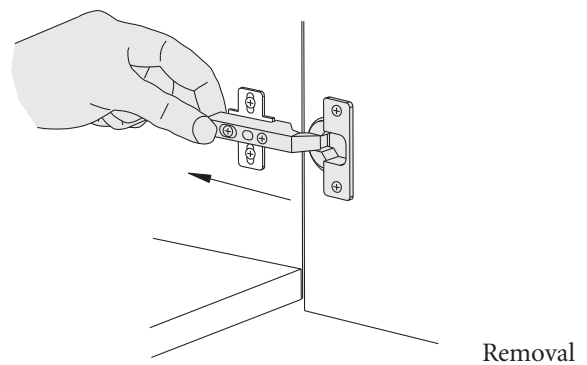

Figure E

